

 ORBITA™





4 DESIGNERS

6 ORBITA

8 ALLINEAMENTI (9 MAY 1126)
Oval table

18 ECLITTICA
Oval table

28 LUNA ROSSA (27 JULY 2018)
Round table

40 LUNA BIANCA
Round table

44 LUNA NERA
Round table



CAROLA FUMAROLA

Carola Fumarola lives and works in Bologna. She graduated in Architecture from the Polytechnic University of Turin, where she studied design under Gabetti & Isola and collaborated as an assistant to Pietro Derossi. These experiences shaped her ability to approach architecture holistically — from the overall design concept to the finest details of interior design.

Since 1995, through her architectural services company Arking srl, she has promoted complex infrastructure projects across Italy. Her work also extends to the restoration of major buildings and the development of concepts for large-scale franchising and commercial projects, overseeing both the creative phase and the development process of the final product for Italian and international brands such as LG and Daikin.

In 2014, she founded ARCADE STUDIO, focusing on civic, residential, and commercial architecture, with particular attention to the contemporary restoration of historic buildings in Rome, Milan, Bologna, and Southern Italy.

The distinctive hallmark of her work lies in her ability to combine the recovery of historical memory with a clean and modern aesthetic, approaching spaces, functions, and architectural elements with sensitivity and refinement. Her research also explores the creative and sophisticated use of diverse materials applied to architecture and custom-designed furnishings.

She has completed the renovation of villas, masserie, convents, and prestigious apartments, as well as projects for commercial spaces, boutique hotels, and representative offices.

Her projects have been featured in several national and international publications, including La fabbrica delle foglie, La casa bestiale, La Baronella, Rinascimento Privato, Vivere il '500, and Fioriture.



VANESSA STELLA

A design architect, he graduated from the University of Florence with a focus on "Protection and Recovery of Architectural Historical Heritage," later specializing in bioarchitecture and feng shui. After his studies and 10 years of private practice, he decided to take over the family business, which has been operating in the furniture sector for over 50 years.

From his passion for art, the UNICA brand was born in 2015, with the ambitious goal of blending spaces with their component elements. The art and decoration of the furnishings thus create unique spaces that perfectly resonate with those who enjoy them day after day. "Art more than anything else gives us the opportunity to enter the field of the unconscious and to interpret, through sign and color, the sensations and desires that allow us to live our spaces to the fullest."

Continued investment in research and innovation together with collaboration with master craftsmen has led to the development of highly personalized products, appreciated both in Italy and abroad.

Today, Vanessa Stella's additional challenge is to consolidate the excellent results achieved in recent years by increasing the company's presence in foreign markets, bringing Made in Italy excellence to every part of the world.



ORBITA™

The “Orbita” collection stems from the desire to create highly representative tables by attributing the poetic idea of form to functionality. The “Eclittica” table, without planets, leaves the sun as the sole protagonist. “Allineamenti” reinterprets one of the rare configurations in the sky, when all the planets find themselves arranged along an imaginary line.

The underlying concept is the essential fusion of form and decoration, stemming from the idea that the elliptical shape of the crystal table top designs the orbit of the planets around the Sun. The whole top is made of stratified crystal, decorated with two-grain golden powders and variegated metallic leaves representing the planets of the solar system. At the base a truncated cone illuminated inside and covered with gold coloured leaf to symbolize the Sun.

Several graphics have been developed for “Eclittica”: tones reminiscent of the celestial darkness illuminated by a sprinkling of golden powder or the white color of the milk that emphasizes the intensity of the light emanated from the base (Sun). The variants of “Orbita” are expressed in the concepts **Luna Nera**, **Luna Bianca** and **Luna Rossa**, the latter in particular offers the possibility of representing the astral positioning on any date at the request of the customer.



“

*Here today, tomorrow elsewhere.
Always in motion. A voyage
that returns once more
to the beginning.*

*Dancing together, in perfect
asynchronicity. Around the core, so
many identities caressed by the golden
rays. Surrounded by darkness.*

”

 **ORBITA**[™]
ALLINEAMENTI / ECLITTICA





TABLE
ALLINEAMENTI
(9 MAY 1126)



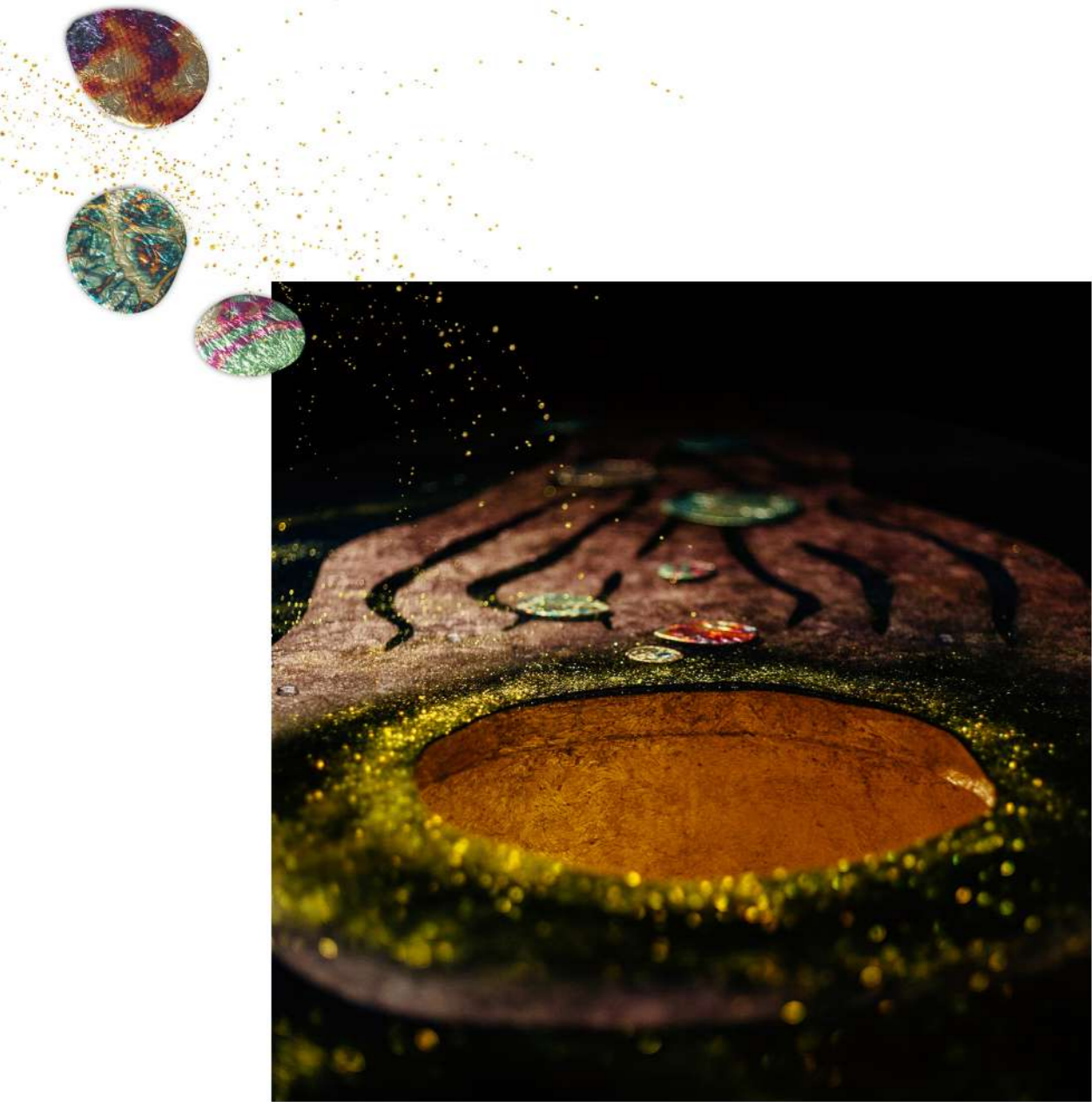

TABLE
ALLINEAMENTI
(9 MAY 1126)



(9 MAY 1126)

ALLINEAMENTI™

"ORBITA" COLLECTION

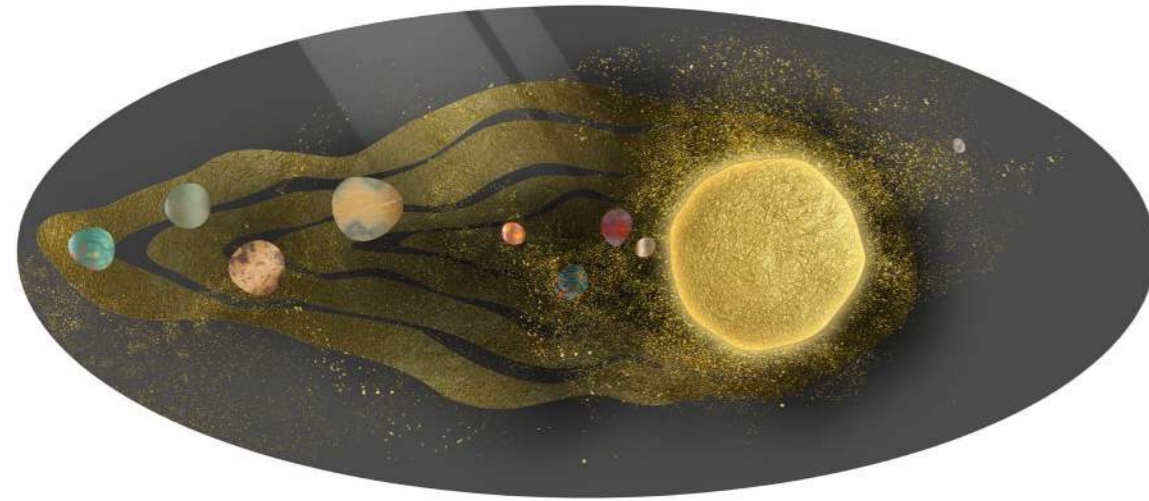

Designers C. FUMAROLA by ARCADE STUDIO and V. STELLA by UNICA

Product features Table with elliptical top in extra-clear, laminated glass, thickness 12 mm., decorated with sandblasting, variegated texture in digital printing on gold coloured leaf, fumè painting, black shades digital printed and *Trilli Effect* (golden powder).

Structure in stainless steel, thickness 5 mm., with matt black paint on the outside and gold coloured leaf finishing on the inside. Aluminum plate, thickness 30 mm., shaped with laser cutting, matt black painting on outer edge and top covered in gold coloured leaf.

Internal led lighting with warm light 15 W, with battery and remote control for on / off.

Dimensions L. 220 cm W. 95 cm H. 80 cm

Weight 150 kg

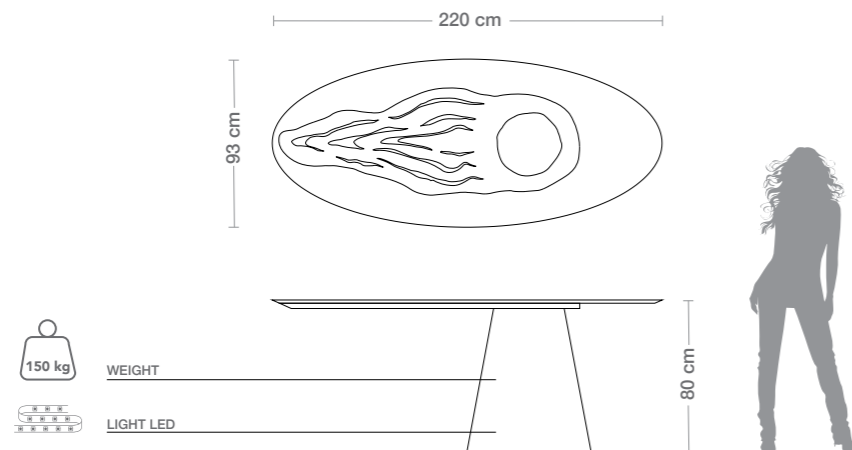

Top



Trilli Effect



Varied texture in digital printing on gold coloured leaf



Sandblasting



Fumè

Base



Gold coloured leaf



Soft touch matt black paint

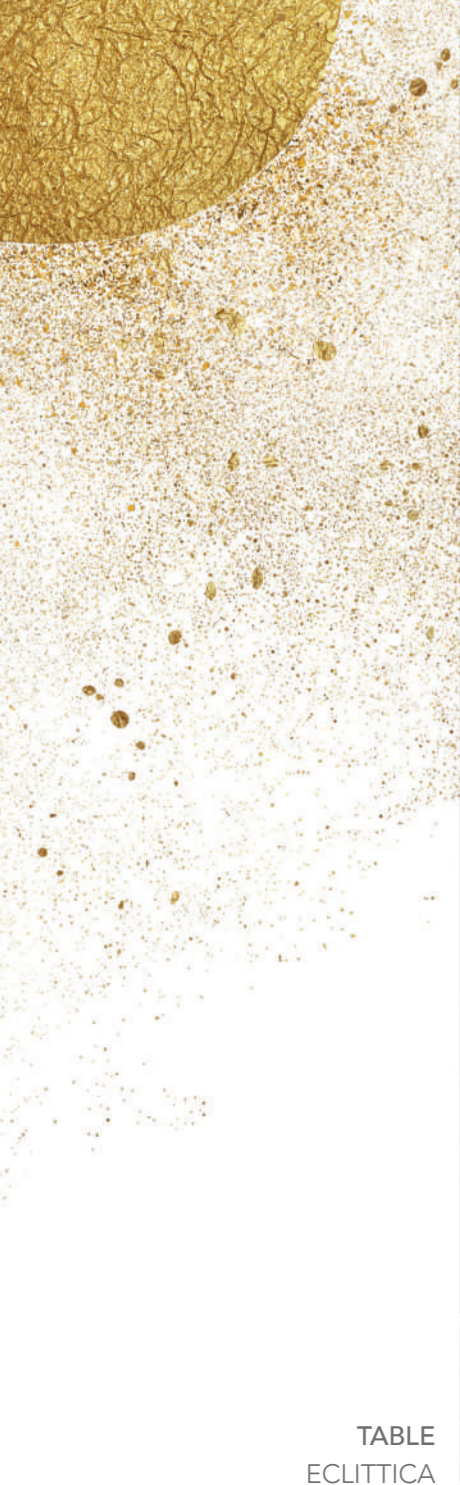
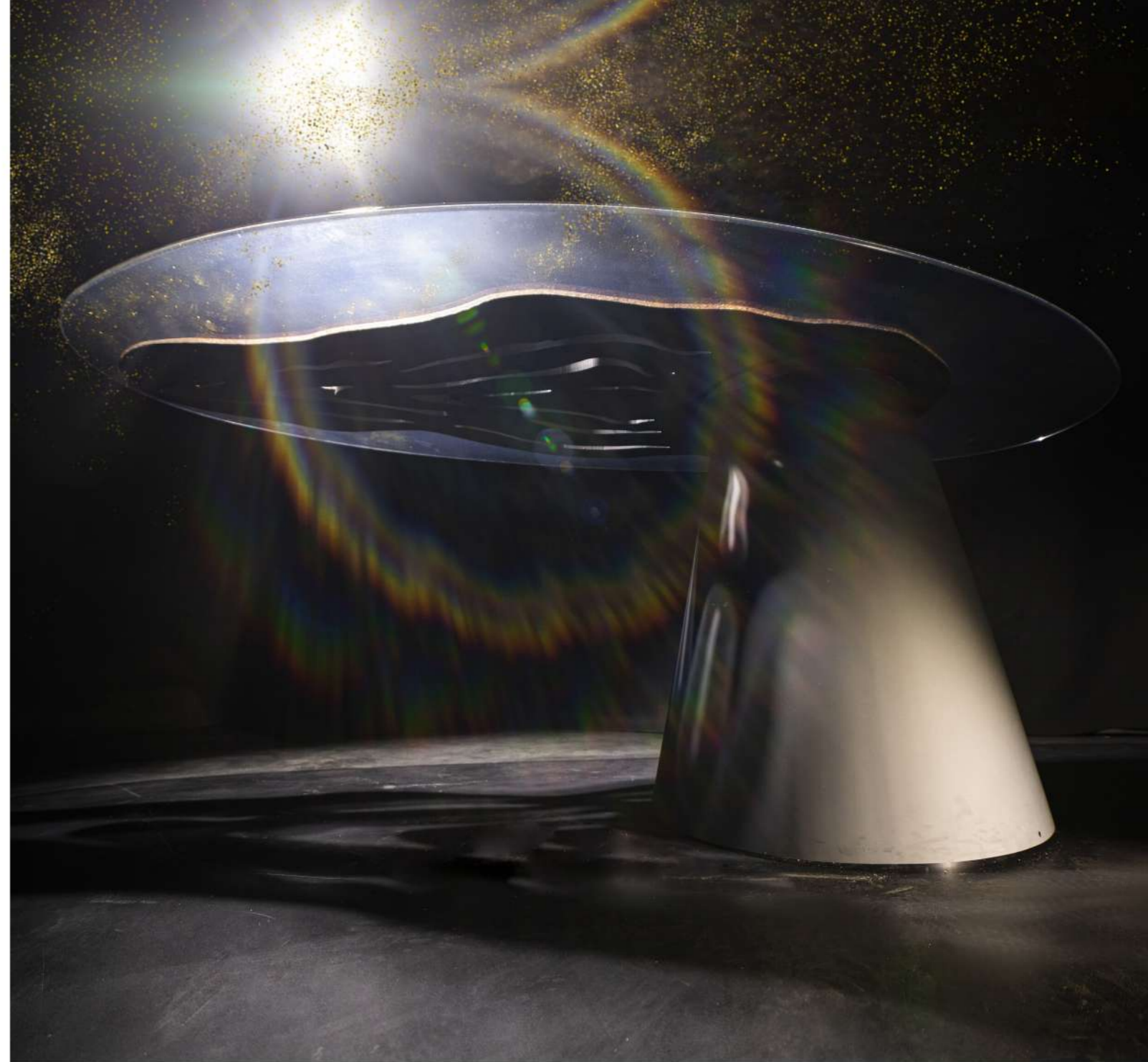

TABLE
ECLITTICA



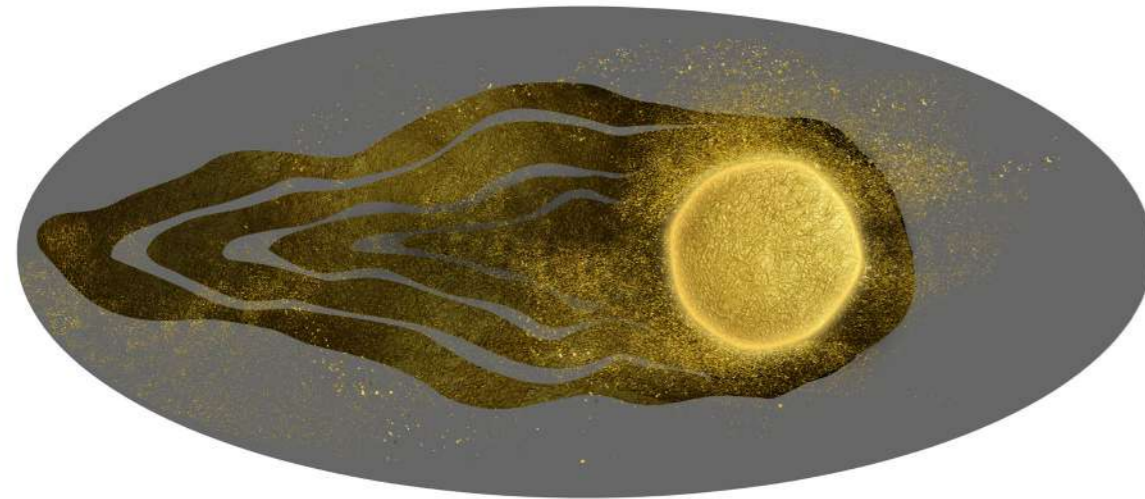

TABLE
ECLITTICA



ECLITTICA NERA™

"ORBITA" COLLECTION



Designers C. FUMAROLA by ARCADE STUDIO and V. STELLA by UNICA

Product features Table with elliptical top in extra-clear, laminated glass, thickness 12 mm., decorated with *Trilli Effect* (golden powder), fumè painting, black shades digital printed.

Structure in stainless steel, thickness 5 mm., with matt black paint on the outside and gold coloured leaf finishing on the inside. Aluminum plate thickness 30 mm., shaped with laser cutting, matt black painting on outer edge and top covered in gold coloured leaf.

Internal led lighting with warm light 15 W, with battery and remote control for on / off.

Dimensions L. 220 cm W. 95 cm H. 80 cm

Weight 150 kg

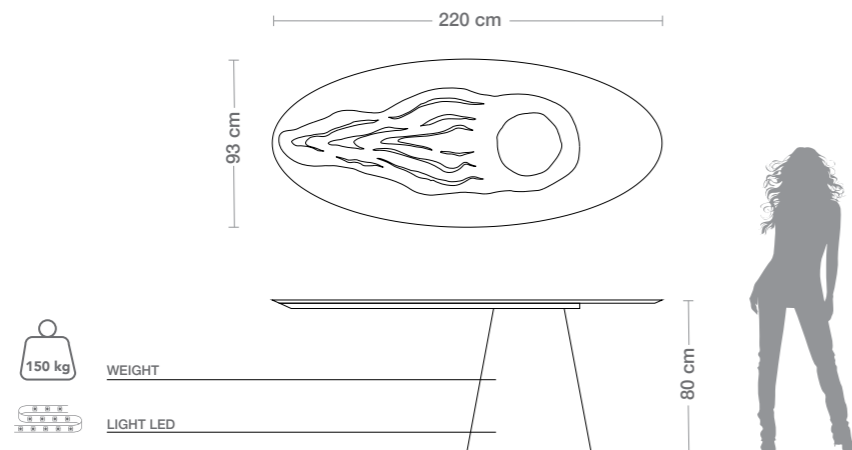

Top



Trilli Effect



Fumè



Digital Printing

Base



Gold coloured leaf



Soft touch matt black paint

ECLITTICA BIANCA™

"ORBITA" COLLECTION



Designers C. FUMAROLA by ARCADE STUDIO and V. STELLA by UNICA

Product features Table with elliptical top in extra-clear, laminated glass, thickness 12 mm., decorated with *Trilli Effect* (golden powder).

Structure in stainless steel, thickness 5 mm., with matt white paint on the outside and gold coloured leaf finishing on the inside. Aluminum plate thickness 30 mm., shaped with laser cutting, matt white painting on the top.

Internal led lighting with warm light 15 W, with battery and remote control for on / off.

Dimensions L. 220 cm W. 95 cm H. 80 cm

Weight 150 kg

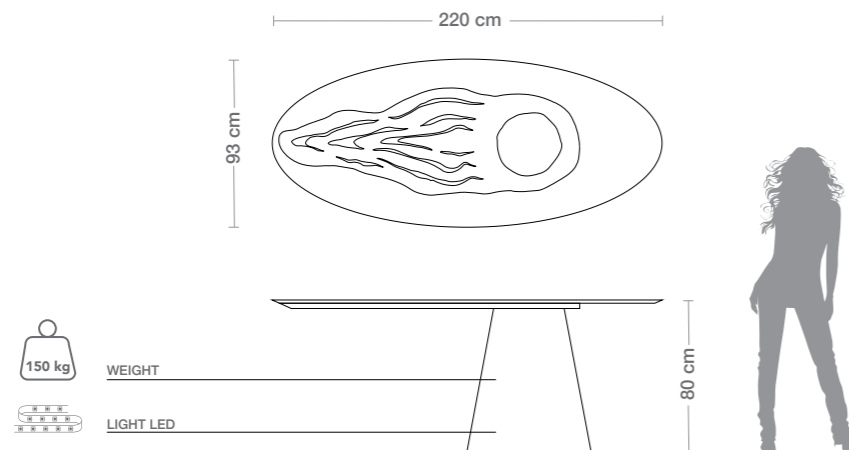

Top



Trilli Effect

Transparent Glass

Base



Gold coloured leaf

Soft touch matt white paint



“

*For millennia, man has looked up
to the sky and probed its depth.*

*He discovers new worlds, traces routes
between the stars, and outlines
the planets.*

”



LUNA ROSSA / LUNA BIANCA / LUNA NERA





TABLE
LUNA ROSSA
(27 JULY 2018)

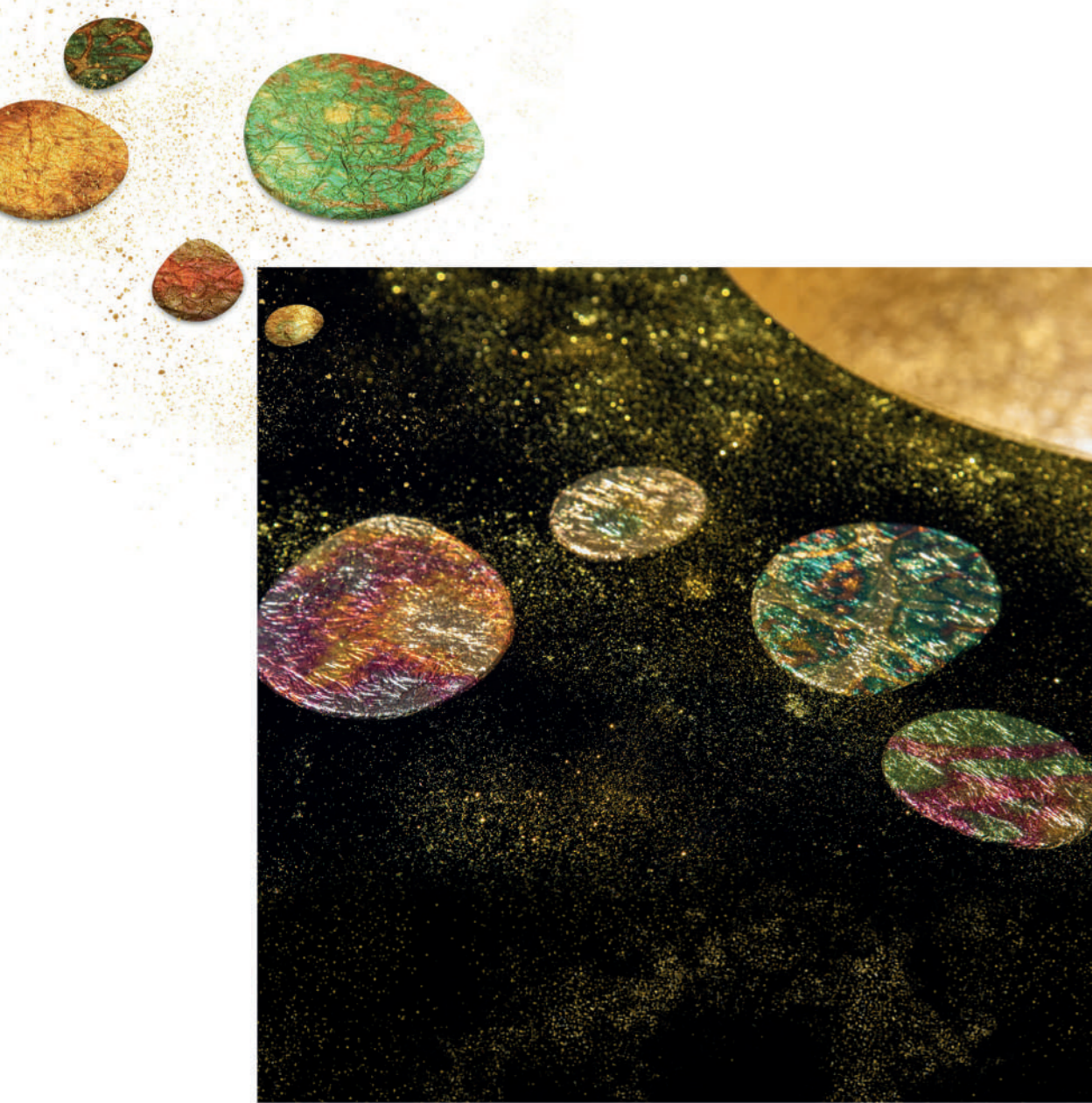

TABLE
LUNA ROSSA
(27 JULY 2018)





TABLE
LUNA ROSSA
(27 JULY 2018)



(27 JULY 2018)

LUNA ROSSA™

"ORBITA" COLLECTION

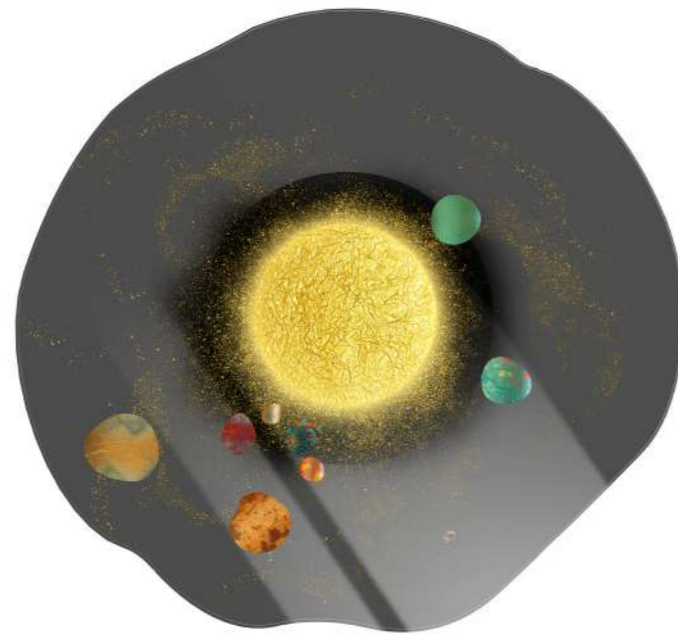

Designers C. FUMAROLA by ARCADE STUDIO and V. STELLA by UNICA

Product features Table with extra-clear shaped glass top, layered, thickness 12 mm., decorated with sandblasting, variegated texture in digital printing on gold coloured leaf, fumè painting, black shades digital printed and *Trilli Effect* (golden powder).

Double stainless steel structure, thickness 2 mm., wooden core, with matt black paint outside and gold coloured leaf finishing inside.

Internal led lighting with warm light 15 W with battery.

Dimensions L. 160 cm W. 160 cm H. 80 cm

Weight 197 kg

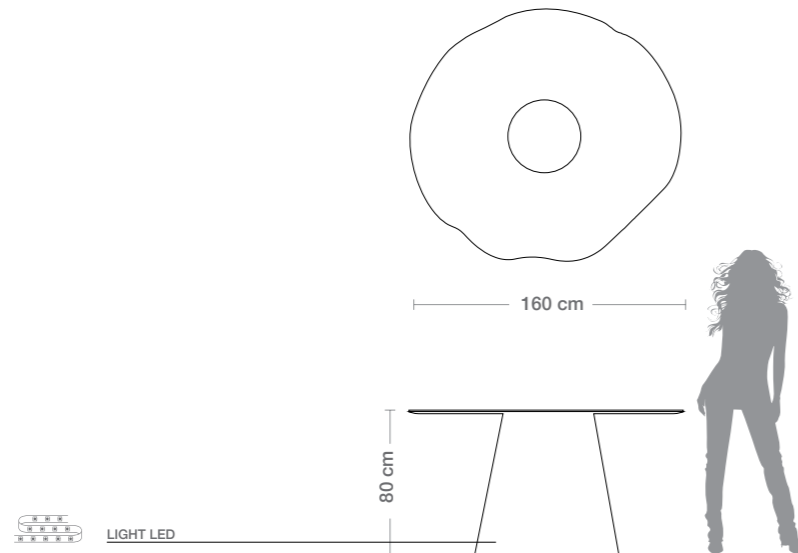

Top



Trilli Effect



Fumè



Varied texture in digital printing on gold coloured leaf



Sandblasting

Base

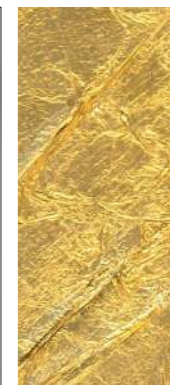

Gold coloured leaf

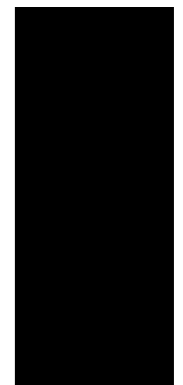

Soft touch matt black paint



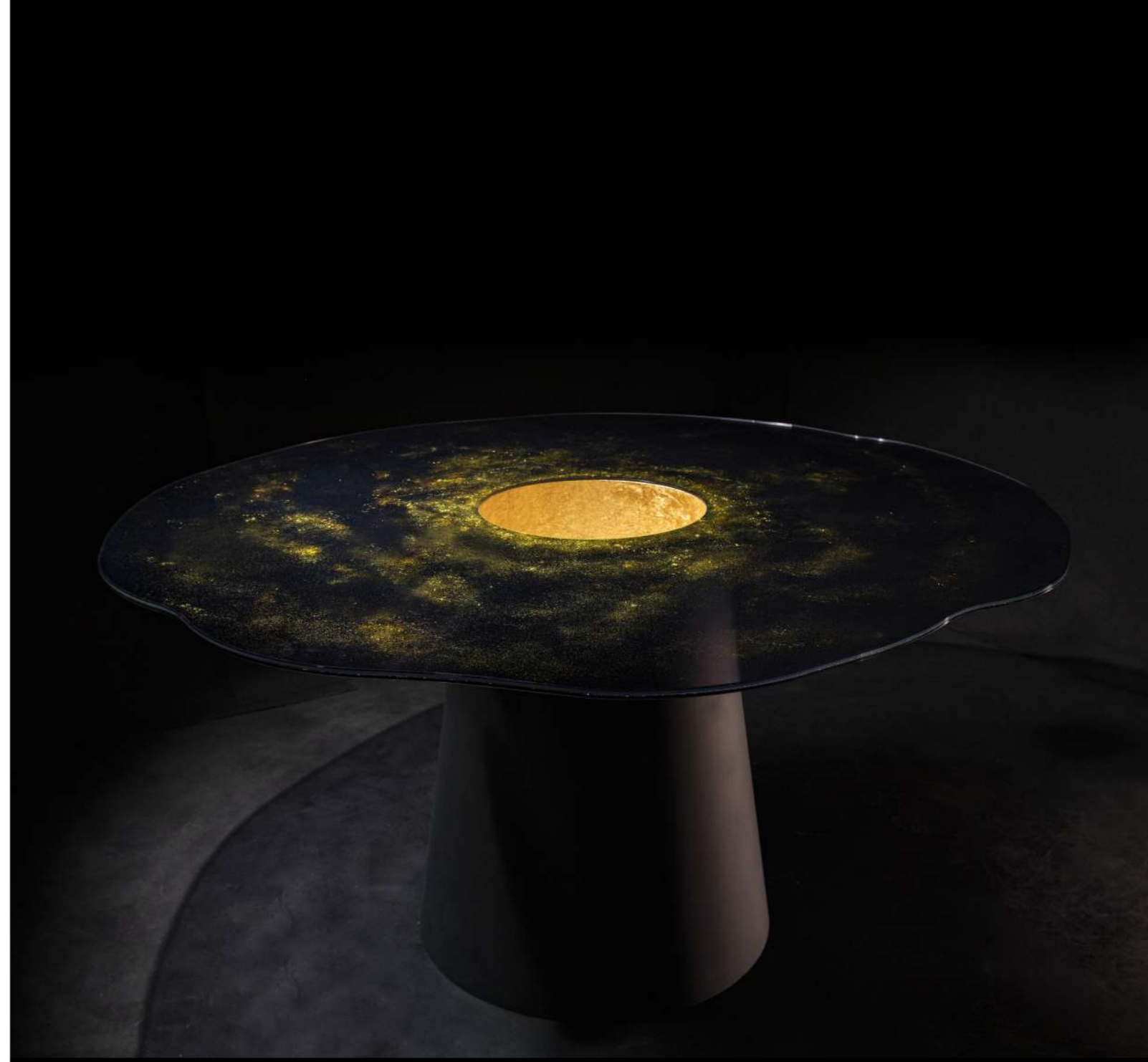

TABLE
LUNA BIANCA





TABLE
LUNA NERA



LUNA BIANCA™

"ORBITA" COLLECTION



Designers C. FUMAROLA by ARCADE STUDIO and V. STELLA by UNICA

Product features Table with extra-clear shaped glass top, layered, thickness 12 mm., decorated with *Trilli Effect* (golden powder).

Double stainless steel structure, thickness 2 mm., wooden core, with matt white paint outside and gold coloured leaf finishing inside.

Internal led lighting with warm light 15 W with battery.

Dimensions L. 160 cm W. 160 cm H. 80 cm

Weight 197 kg

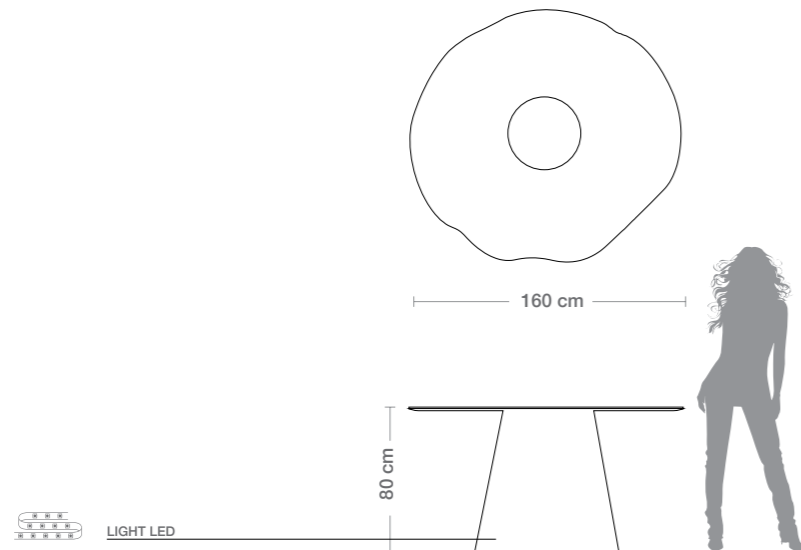

Top



Trilli Effect

Transparent Glass

Base



Gold coloured leaf

Soft touch matt white paint

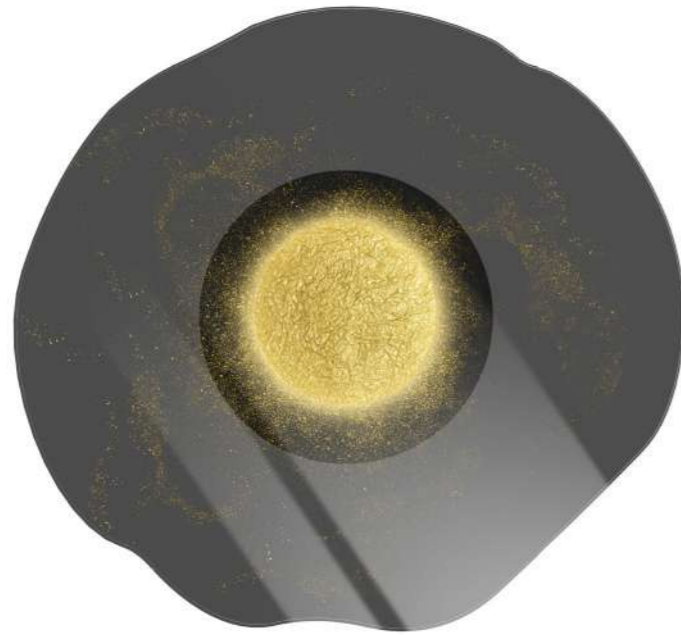

LUNA NERA™

"ORBITA" COLLECTION



Designers C. FUMAROLA by ARCADE STUDIO and V. STELLA by UNICA

Product features Table with extra-clear shaped glass top, layered, thickness 12 mm., fumè painting, black shades digital printed and *Trilli Effect* (golden powder).

Double stainless steel structure, thickness 2 mm., wooden core, with matt black paint outside and gold coloured leaf finishing inside.

Internal led lighting with warm light 15 W with battery and remote control for on / off.

Dimensions L. 160 cm W. 160 cm H. 80 cm

Weight 197 kg

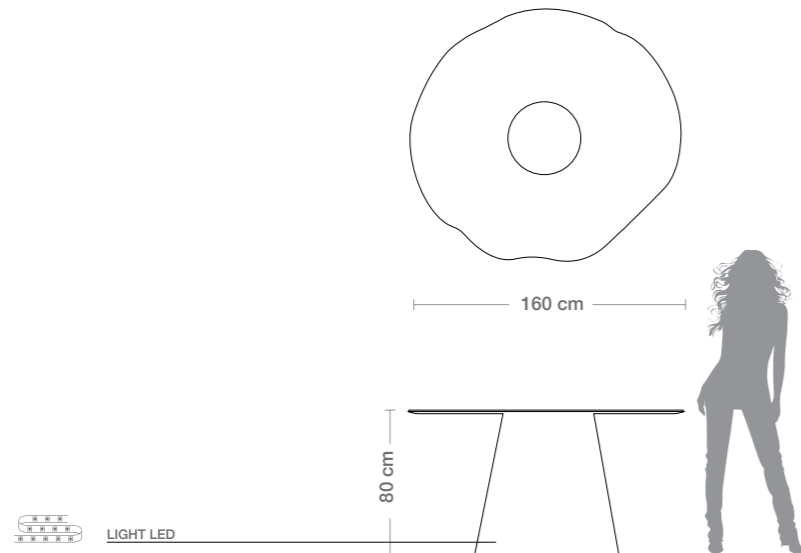

Top



Trilli Effect



Fumè



Digital Printing

Base

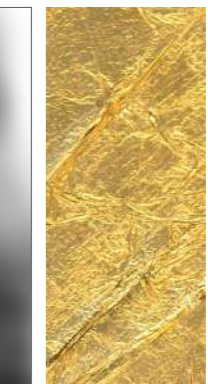

Gold coloured leaf



Soft touch matt black paint



Luxury Bespoke Tables

VIA BONAZZI 4, CASTEL MAGGIORE (BO) 40013 ITALY
T. +39 051 0930634 INFO@UNICALUXURY.COM UNICALUXURY.COM



MADE IN ITALY
